

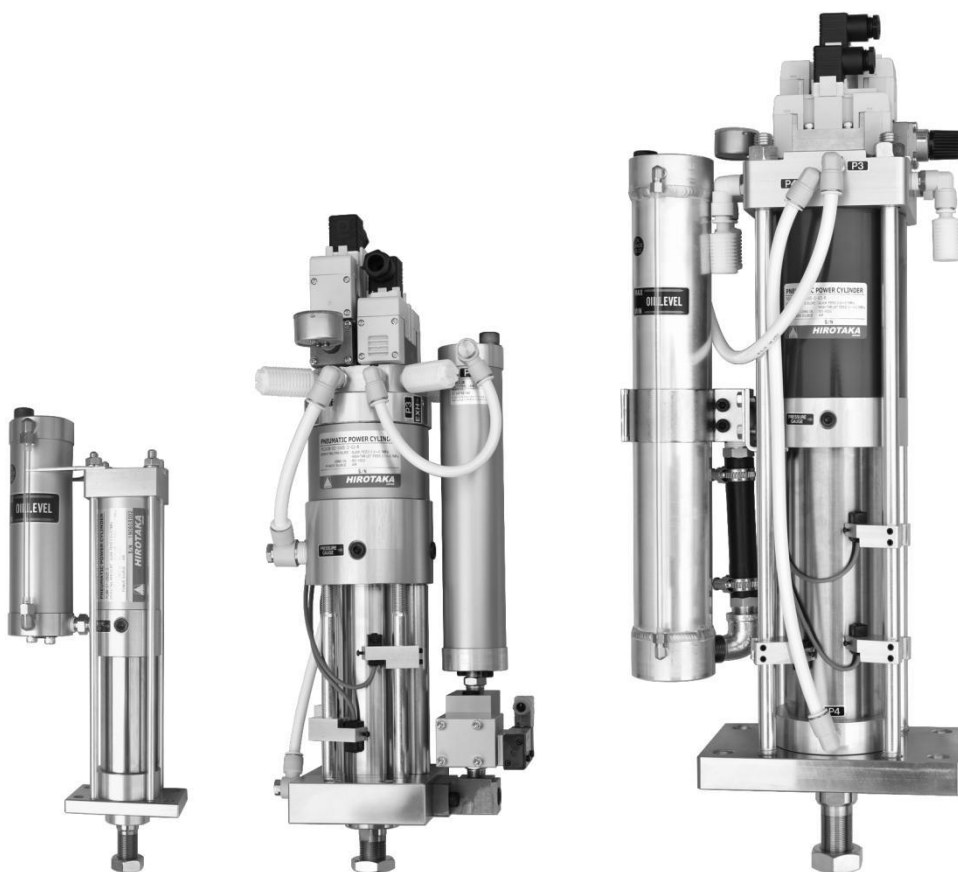

# MANUAL

# PNEUMATIC POWER CYLINDER



**HIROTAKA MFG. CO., LTD.**

 **The notes for Using**  
Be sure to read this before handling

 **CAUTION**

1. **Piping**

Before installing the piping, blow compressed air to prevent dirt from entering the piping. Due to the structure of the pneumatic power cylinder, oil may be discharged from each air port due to wear or damage to the seals. We recommend installing an exhaust cleaner in the exhaust port of the valve.

2. **Air supply**

Using the compression air with dry via filter. The operating pressure is 0.7 MPa or less.

3. **Hydraulic fluid (ISO VG22 Standard mineral hydraulic fluid or VG32)**

If the hydraulic fluid has drain or dirt mixed in with it, or if it has deteriorated or discolored, replace it with new hydraulic fluid. Also, use the same old and new hydraulic oil. Recommended to replace once a year.

4. **Quantity of oil**

There is an oil level tube on the side of the converter, so please replenish the hydraulic oil when the oil level drops. Check the oil level with the cylinder stopped (Piston rod retraction end).

5. **Mounting direction**

Mount the pneumatic power cylinder so that the piston rod is oriented downward.

If it will mount upward or horizontally, the standard model cannot use it. Please contact us before your order and consideration.

**Attach a plug to P3 port by all means when you carry a cylinder and send it. Don't flow out oil inside the cylinder.**

Carry out an air vent every one or two months in case of the model with air release valve.

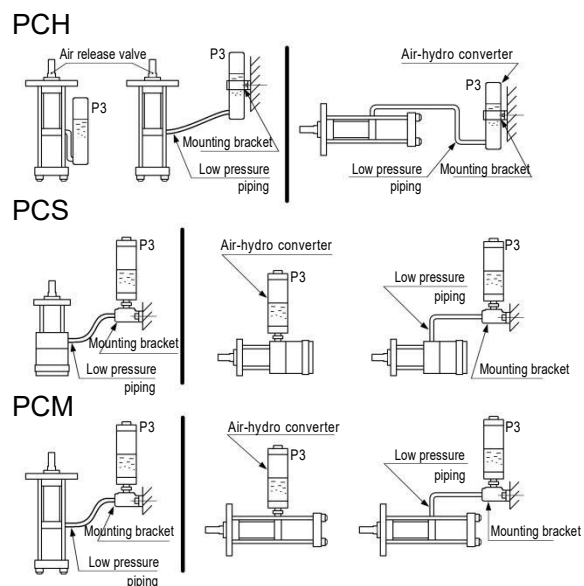

Capacity of oil			Unit : liter			
Model	Type of total stroke	Capacity	Model	Type of total stroke	Capacity	
PCM-005, 01	05	0.20	PCH-03, 06, 08	15	1.60	
	10	0.30		20	1.90	
	15	0.40		30	2.50	
	20	0.45		PCH-13, 17, 24	10	2.70
	30	0.55			15	3.40
PCS-02, 04	05	0.35	PCH-35, 44	20	4.10	
	10	0.45		30	6.20	
	15	0.55		10	3.80	
	20	0.75		15	4.70	
	30	0.95		20	5.60	
PCH-03, 06, 08	10	1.00		30	7.40	

# Preparations before the use ( All models )

## 1. Return a piston rod to the backward end position.

Place the Pneumatic Power Cylinder on the machine frame, and construct the air piping.

Supply a compressed air to P2 and P4, make situation that returned a piston rod and a booster.

The type with operating valve, when air is supplied to the IN-port, it is supplied to the P2 and P4 port. (Operating valve is OFF)

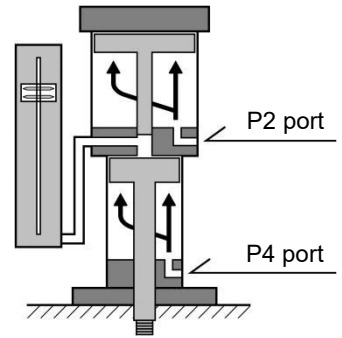

### **CAUTION**

#### The model with pressure gauge (Option)

The pressure gauge of a model with pressure gauge is packed separately, and it is shipped. Remove the R1/4 plug next to the "PRESSURE GAUGE" label before supplying compressed air. Wrap sealing tape around the threads of the pressure gauge and attach it. Oil will not drip if the plug is removed with the pressure gauge port pointing upward, but when the plug is removed with the cylinder upright, a small amount of oil will drip. Remove the plug while receiving oil with a waste cloth, etc., and then attach the pressure gauge. When installing a pressure gauge after supplying air, be sure to do so in the state of 1 above. Please be careful when there is pressure inside the cylinder (P1, P3 port) as oil may flow out or scatter. "The PCM and PCS types are pre-filled with oil. Be careful not to flow out or scatter."

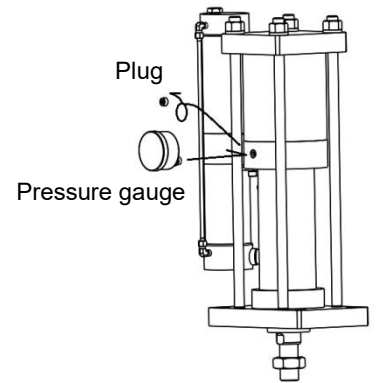

## 2. Oiling

When adding oil, be sure to put oil in the state of 1. Remove the oil cap on the top of the air-hydro converter and add oil. If it remove the P3 port piping, it will be easier for oil to enter. The oil level of air-hydro converter rise speed of the oil gauge is slower than the actual amount of oil, so please add it slowly when it reaches near the oil level. It is recommended to use mineral hydraulic oil with a viscosity equivalent to VG22. After the oil has entered, tighten the oil cap firmly and connect the P3 port piping. "PCM and PCS types are pre-filled with oil. Remove the plug from the P3 port before piping. Also, remove the plug and connect the attached air pipe for the type with operating valve."

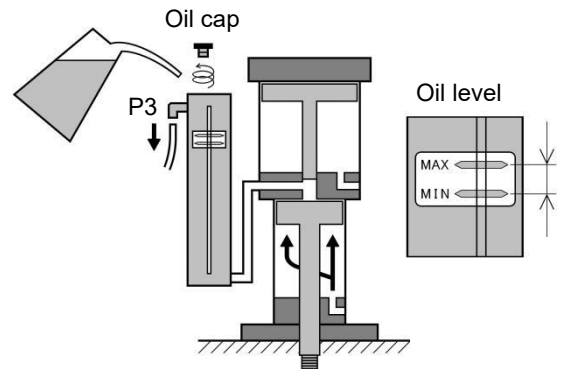

## 3. Air releasing "Repeat pneumatic thrust stroke"

By manually operating the pneumatic thrust stroke solenoid valve (SOL-1), release remaining air. Operate the manual button of the solenoid valve to extend the piston rod to the stroke end and then return the piston rod. After returning to the backward end position, wait about 5 seconds to release the air in the oil in the air-hydro converter. Do this action about 5 times. When the air is released and the oil level drops, add oil to the appropriate amount.

Note: For type with a stop valve, push the manual button on the solenoid valve that comes with the stop valve. Do this with the stop valve open.

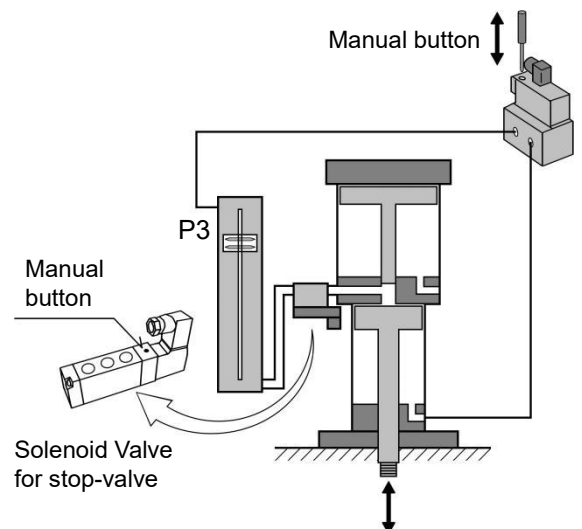

# Preparations before the use ( Type with options )

## A. Type with operating valve (Symbol : PCMV\*, PCSV\*, PCHV\*)

Air piping is for IN port only. Pipe the source pressure directly. The P3 port is delivered with the fitting removed, so mount it in the equipment, remove the plug after standing upright, and then perform piping. The PCSV\* model comes with 3 silencers, so please attach them to each exhaust port.

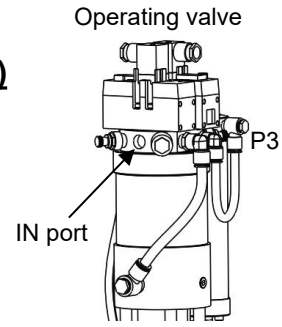

## B. Type with auto switch (Symbol : PCMW, PCSW, PCHW)

The switch mounting position at the time of shipment is provisional. Adjust to the proper position after the equipment can be operated, such as air piping and electrical wiring. The orientation of the switch can be changed by reversing the mounting bracket or by mounting the switch in the opposite direction. Make sure the switch is in close contact with the cylinder tube.

- (b-1) Piston rod backward end position  
Adjust so that the switch turns ON when the piston rod is completely returned.
- (b-2) Start position of high thrust stroke  
Adjust to the contact position of the JIG and workpiece after the pneumatic thrust stroke operation.
- (b-3) High thrust stroke completion position  
Adjust to the position where the high thrust stroke is completed. It can adjust the position more finely by sliding it upward from the piston rod side and adjusting it to the ON position.

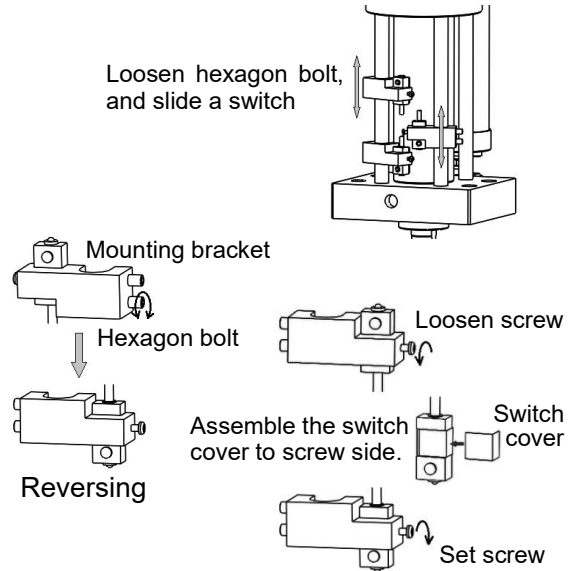

## C. Type with stop valve (Symbol : - V\*)

Connect the air piping to the attached solenoid valve. The center port is the air supply port. Supply the source pressure. The stop valve is open when shipped. When air is supplied, the stop valve closes. A silencer for the exhaust port is not included, so please install an R1/8 silencer.

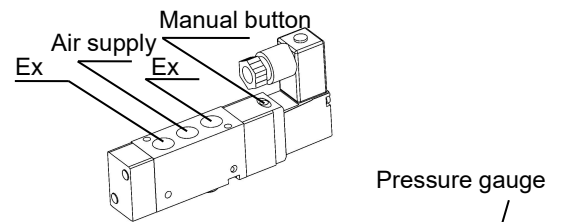

## D. Type with regulator (Symbol : R)

Used to adjust high thrust to a thrust lower than the supply pressure. Refer to the thrust table on page 19 for pressure setting. The regulator pressure increases only when the high thrust solenoid valve is turned ON. Adjust while watching the pressure gauge attached to the regulator during high thrust stroke.

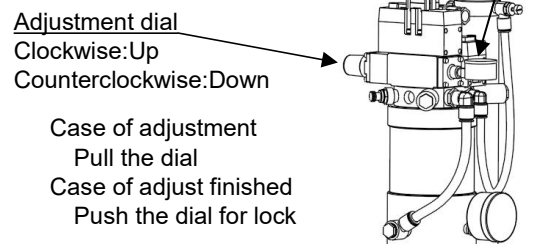

## E. Type with drop prevention valve (Symbol : T)

When the compressed air supplied to the IN port disappears, the air in the pneumatic thrust stroke (inside the P3 and P4 port) is sealed. The piston rod thereby retains the retraction force. To operate the cylinder again, supply air to the IN port. A residual pressure release is not included, so if it is necessary to release the residual pressure, loosen the mounting screw of the pneumatic thrust stroke valve to release the air, or branch the air piping and install a separate residual pressure release.

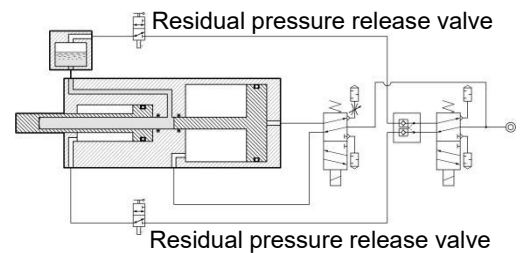

## F. Type with oil film removal specification for rod (Symbol : B)

Pipe the drain port (Rc1/8) and install a drain pan near the cylinder. The leaked oil will drain to the exhaust of the solenoid valve.

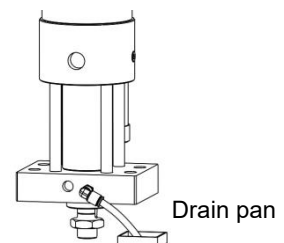

# Operation adjustment method

Adjust the operation of the cylinder by adjusting or installing parts as shown below.

Motion	Adjustment method
Adjustment of pneumatic thrust stroke speed	Install speed controller of the meter out in P4.
Adjustment of high thrust stroke speed	Install speed controller of the meter out in P2.
Adjustment of high thrust stroke return speed	Install speed controller of the meter out in P1. Adjust silencer with speed controller. (Type with operating valve)
Adjustment of backward speed	Install speed controller of the meter out in P3.
Adjustment of high thrust	Install regulator with backflow function in P1. Adjust regulator. (Type with operating valve and regulator)
Adjustment of pneumatic thrust stroke thrust	Install regulator with backflow function in P3.
Add top dead center to mid-stroke position (Switching of top dead center, Emergency stop)	After adjusting the auto switch to the new top dead center, off the stop valve while the piston rod is returning.
Speed up	Increase supply air pressure. (Booster regulator)
	Install quick exhaust valve in P4 or P2. (But the life of seal shortens.)
	Make the air piping thicker and shorter. Also consider the size of the pneumatic equipment.
	Use supporting air cylinder. (Backward stroke speed)

## Drop prevention

When the compressed air inside the cylinder(P4) runs out, the load may drop due to its weight. In that case the following method can be dealt with. The same applies to the type with stop valve. However, ① and ④ may not be retained for a long time.

### Method of drop prevention

- ① Use a pneumatic thrust stroke solenoid valve of a closed center type (Perfect type) to seal the air in the P4 port. Or install a pilot check valve on the P4 port piping.
- ② Attach a mechanical brake to the jig guide.
- ③ Provide a mechanical stopper at the upward end (effective only when waiting for the upward end).
- ④ For models with an operation valve, install the optional drop prevention valve.

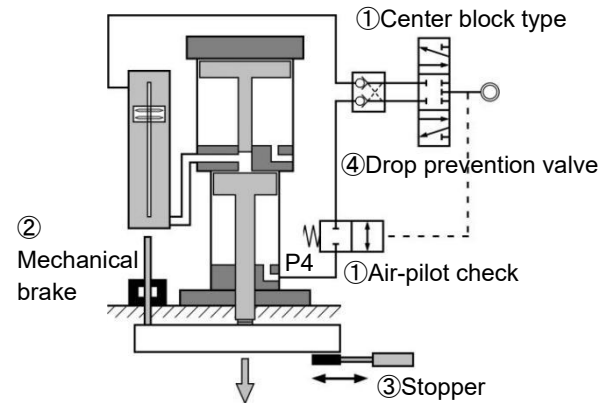

## Oil maintenance

Hydraulic oil deteriorates and turns black with repeated use. Hydraulic oil is also used as a lubricant, so replace the deteriorated or blackened hydraulic oil. (Recommended replacement period : One year)

### Replacement method (with air supplied)

- ① Set the piston rod back as shown in the illustration.
- ② Remove the P3 port piping.
- ③ Remove the plug from the drain port at the bottom of the air-hydro converter and drain the oil. Hydraulic oil will come out vigorously, so use a cylindrical plastic bag to prevent scattering.
- ④ After draining the oil, apply a sealing material to the plug and attach it to the drain port.
- ⑤ Add new hydraulic oil from the oil cap to the appropriate amount within the oil level.
- ⑥ Connect the oil cap, piping and bleed the air (see page 14).

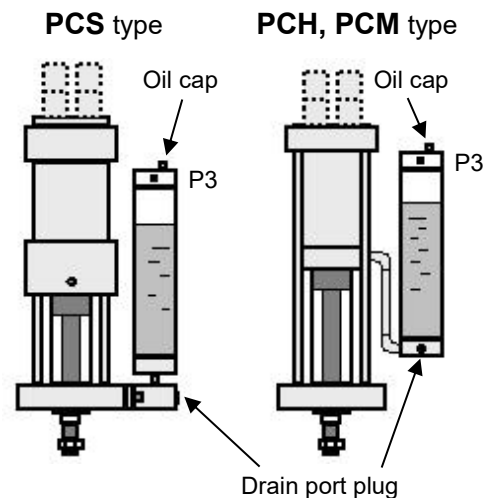

Note: For the type with a stop valve, drain the oil with the solenoid valve of the stop valve turned on.

## Example for air circuit

PCM  
PCS  
PCH

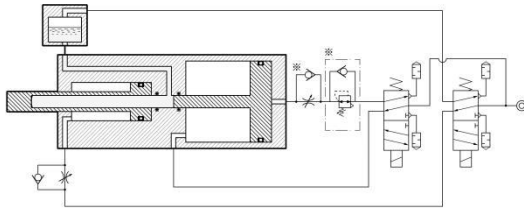

Install the regulator when adjusting high thrust. The position shown in the figure or the primary side of SOL-2 (For SOL-2 primary side, use a pressure reducing valve without backflow function). Speed controller (P1) should be installed in the direction shown in the illustration to prevent negative pressure in the oil. Be sure to install it. For speed adjustment, install a speed controller on each port. (see page 16)

The type with operating valve

PCMV\*  
PCSV\*  
PCHV\*

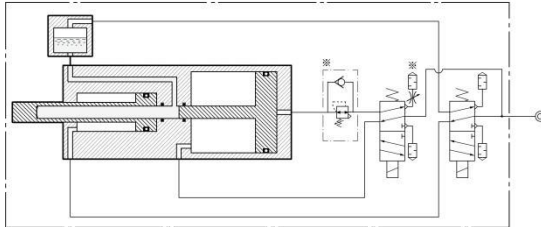

Supply air to the IN port.  
The regulator (option) is for high thrust adjustment.  
Speed controller (optional) for each port can be retrofitted in-line.

"circle mark" indicates supply, "cross mark" indicates exhaust.

Operating condition	SOL-1	SOL-2	P1	P2	P3	P4	Progress condition
Stop	OFF	OFF	×	○	×	○	Condition of illustration
Pneumatic thrust stroke	ON	OFF	×	○	○	×	Forward at fast speed
High thrust stroke	ON	ON	○	×	○	×	Forward at high thrust
Backward drive	OFF	OFF	×	○	×	○	Return at fast speed

## Example for air circuit

The type with stop valve

PCM...V\*  
PCS...V\*  
PCH...V\*

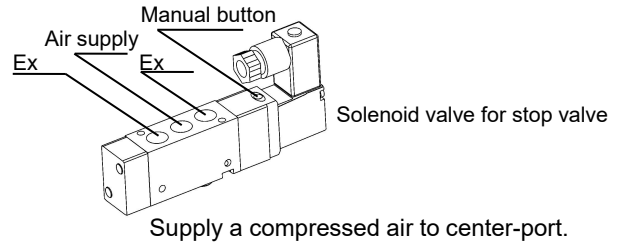
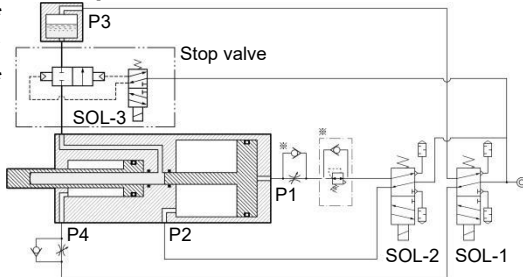

How to intermediate stop (Emergency stop, Inching)

"circle mark" indicates supply, "cross mark" indicates exhaust.

Operating condition	SOL-1	SOL-2	SOL-3	P1	P2	P3	P4	Progress Condition
Stop	OFF	OFF	OFF	×	○	×	○	Condition of illustration
Pneumatic thrust stroke	ON	OFF	ON	×	○	○	×	Forward at fast speed
Intermediate stop	OFF	OFF	OFF	×	○	×	○	Intermediate stop
High thrust stroke	ON	ON	ON	○	×	○	×	Forward at high thrust
Backward drive	OFF	OFF	ON	×	○	×	○	Return at fast speed

It does not stop during the high thrust stroke, stop after the high thrust stroke returns.

How to continuous operation for high thrust stroke drive only

"circle mark" indicates supply, "cross mark" indicates exhaust.

Operating condition	SOL-1	SOL-2	SOL-3	P1	P2	P3	P4	Progress Condition
① Stop	OFF	OFF	OFF	×	○	×	○	Condition of illustration
② Pneumatic thrust stroke	ON	OFF	ON	×	○	○	×	Forward at fast speed
③ High thrust stroke	ON	ON	ON	○	×	○	×	Forward at high thrust
④ High thrust stroke return drive	OFF	OFF	OFF	×	○	×	○	Return at (High thrust + $\alpha$ ) stroke
⑤ High thrust stroke	OFF	ON	OFF	○	×	×	○	Forward at ( $\alpha$ + high thrust) stroke
⑥ Backward drive	OFF	OFF	ON	×	○	×	○	Return at condition of illustration

(Note1) The  $\alpha$  stroke is a stroke that returns by  $\alpha$  mm from the position at the start of high thrust stroke drive.

There is no high thrust during  $\alpha$  stroke advancement. The  $\alpha$  stroke of each model is shown in the table below.

Model	$\alpha$ stroke (mm)	Model	$\alpha$ stroke (mm)
PCS-02-V*	About 5.5	PCH-13-V*	About 2.0
PCS-04-V*	About 3.1	PCH-17-V*	About 1.8
PCH-03-V*	About 2.1	PCH-24-V*	About 1.4
PCH-06-V*	About 3.6	PCH-35-V*	About 4.5
PCH-08-V*	About 2.8	PCH-44-V*	About 1.8

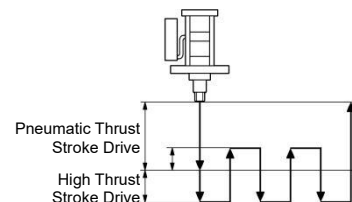

(Note1)

(Note1)

## Solenoid valve, Auto switch

Operating valve (PCSV*, PCHV*)	Stop valve (PCS----V*, PCH----V*)
<p>Improper connection of terminals can lead to problems such as the malfunctioning of solenoid valves. Carefully study the following diagram before connection.</p> <p>Electric connection circuit diagram</p> <p>Single solenoid</p>	<p>Improper connection of terminals can lead to problems such as the malfunctioning of solenoid valves. Carefully study the following diagram before connection.</p> <p>Electric connection circuit diagram</p> <p>Single solenoid</p>

## Auto switch

Read auto switch			Internal circuit	
Model No.	RS-6			
Voltage	24 VDC	100 V / 200 VAC		
Max. switching current	20 mA	20 mA		
Max. switching capacity	5 W	5 VA		
Average operating time	1 mSEC			
Insulation resistance	100 MΩ or more (500 VDC measured via megger)			
Impact resistance	30 G			
Working temperature range	-10 to 60°C (Non-freezing)			
Lead wire	Two - core cable, 1 m			
Indicating lamp	Red LED illuminates when turned ON			
Solid state auto switch				Internal circuit
Model No.	H2ME			
Output type	NPN			
Voltage	5, 12, 24 VDC			
Max. Load current	5 mA (5 VDC), 10 mA (12 VDC), 20 mA (24 VDC)			
Max. switching current	100 mA (5 VDC), 200 mA (24 VDC)			
Internal voltage drop	0.6 V or less (24 VDC)			
Max. Leakage current	0.1 mA or less (24 VDC)			
Impact resistance	30 G			
Working temperature range	-10 to 60°C (Non-freezing)			
Lead wire	Three - core cable, 1 m			
Indicating lamp	Red LED illuminates when turned ON			

## Part name for type with operating valves (Top view)

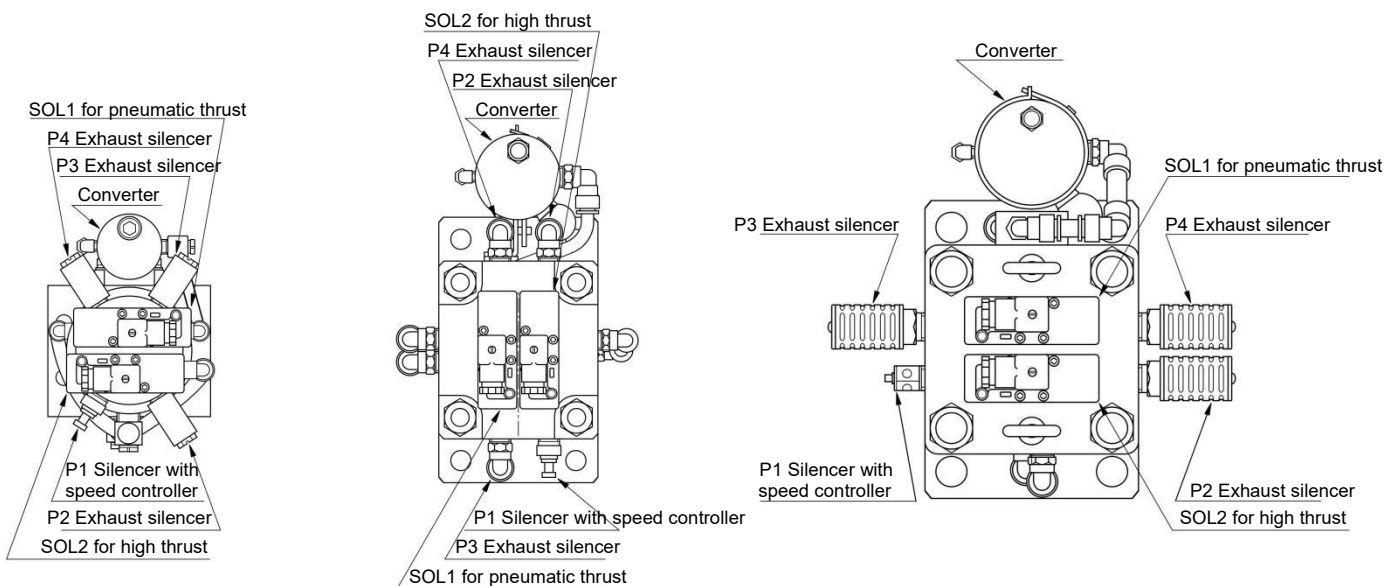

Model : PCSV\*-02, 04

Model : PCHV\*-03, 06, 08

Model : PCHV\*- 13, 17, 24

## Thrust Table

Unit : kN (Theoretical Value)

Air Pressure (MPa)	Model	PCM	PCM	PCS	PCS	PCH	PCH	PCH	PCH	PCH	PCH	PCH	PCH
		005	01	02	04	03	06	08	13	17	24	35	44
High Thrust	0.1	0.78	1.60	3.14	6.06	4.90	8.72	12.56	19.63	24.85	34.39	49.52	63.61
	0.2	1.57	3.20	6.28	12.12	9.81	17.45	25.13	39.26	49.70	68.79	99.05	127.23
	0.3	2.35	4.80	9.42	18.18	14.72	26.17	37.69	58.90	74.55	103.18	148.58	190.85
	0.4	3.14	6.41	12.56	24.24	19.63	34.90	50.26	78.53	99.40	137.58	198.11	254.46
	0.5	3.92	8.01	15.70	30.30	24.54	43.63	62.83	98.17	124.25	171.97	247.64	318.08
	0.6	4.71	9.61	18.84	36.36	29.45	52.35	75.39	117.80	149.10	206.37	297.17	381.70
	0.7	5.49	11.21	21.99	42.42	34.36	61.08	87.96	137.44	173.95	240.76	346.70	445.32
Pneumatic Thrust	0.3	0.37	0.37	0.58	0.58	1.50	1.50	1.50	3.68	3.68	3.68	5.30	5.30
	0.4	0.50	0.50	0.78	0.78	2.01	2.01	2.01	4.90	4.90	4.90	7.06	7.06
	0.5	0.62	0.62	0.98	0.98	2.51	2.51	2.51	6.13	6.13	6.13	8.83	8.83
	0.6	0.75	0.75	1.17	1.17	3.01	3.01	3.01	7.36	7.36	7.36	10.60	10.60
	0.7	0.87	0.87	1.37	1.37	3.51	3.51	3.51	8.59	8.59	8.59	12.37	12.37
Return	0.3	0.28	0.28	0.44	0.44	1.13	1.13	1.13	2.83	2.83	2.83	3.39	3.39
	0.4	0.37	0.37	0.58	0.58	1.50	1.50	1.50	3.77	3.77	3.77	4.52	4.52
	0.5	0.47	0.47	0.73	0.73	1.88	1.88	1.88	4.72	4.72	4.72	5.65	5.65
	0.6	0.56	0.56	0.88	0.88	2.26	2.26	2.26	5.66	5.66	5.66	6.78	6.78
	0.7	0.65	0.65	1.03	1.03	2.63	2.63	2.63	6.61	6.61	6.61	7.91	7.91

## Oil leakage

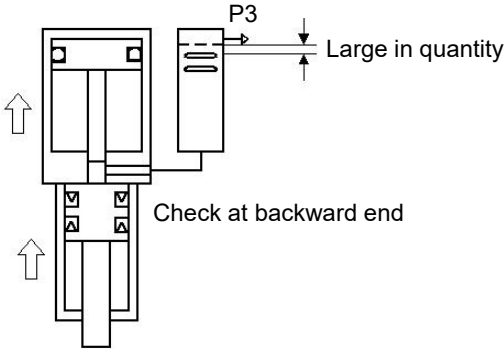
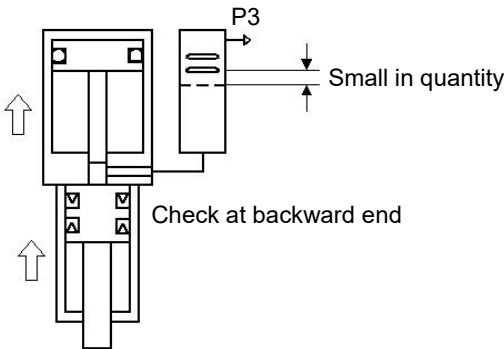
 <p>Illustration 1</p>	<p><b>⚠ CAUTION</b></p> <p>Cause of issue Too much oil will leak from the P3 port.</p> <p>Countermeasures Drain excess oil and adjust to proper level.</p>
 <p>Illustration 2</p>	<p><b>⚠ CAUTION</b></p> <p>Cause of issue If there is not enough oil, air will enter the oil during operation and air bubbles will appear. It will leak out of the P3 port due to the increased amount of oil it looks like. Also, since the ability is used to crush air bubbles during high thrust stroke, insufficient high thrust or insufficient stroke may occur.</p> <p>Countermeasures Add oil and adjust to proper level.</p>

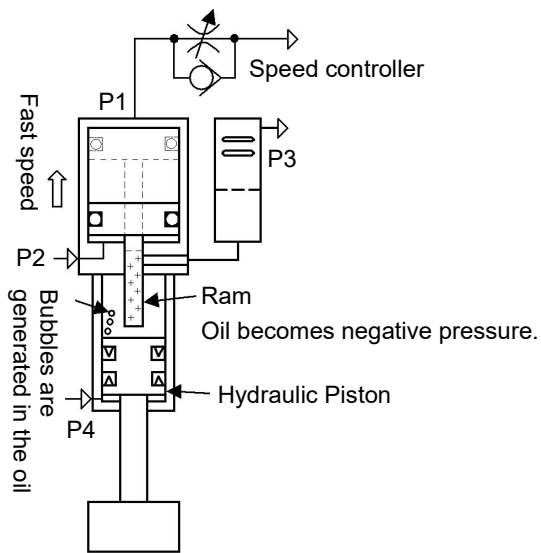

Illustration 3

**Cause of issue**

At the start of ascent, high thrust retraction and pneumatic thrust retraction are performed at the same time. At that time, if the exhaust from the P1 port is fast, the Ram rises quickly and the hydraulic piston cannot keep up with the rise, causing negative pressure in the oil. In this state, small bubbles are generated in the oil, and the apparent amount of oil increases and may leak from the P3 port. Also, since the ability is used to crush air bubbles during high thrust strokes, insufficient high thrust or insufficient stroke may occur.

**Countermeasures (Return stroke)**

When the speed controller of P1 is throttled, the initial backward the high-thrust stroke backwards slowly, and when it ends, it becomes a quick-backward stroke. Gradually open the speed controller and adjust the overall speed to the same speed as fast return. Do not open the speed controller any further. If you open it any further, the oil will become negative pressure, so squeeze it as much as possible before use.

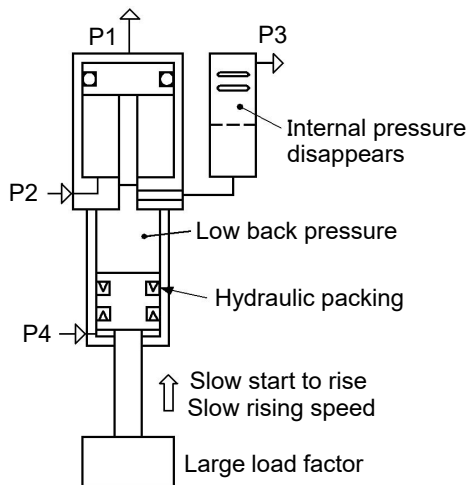

Illustration 4

**CAUTION**

**Cause of issue**

If the load factor is large, the rise start will be slow and the rise speed will be slow. In this case, the pressure in the P3 port disappears (lowers) and the oil back pressure drops. At this time, the tension of the hydraulic packing is reduced and oil leakage may occur on the P4 side.

**Countermeasures (Illustration 5)**

1. Lower the load factor.
2. Pull up with a spring, auxiliary cylinder, etc..
3. Increase air pressure.
4. Install a pressure controller in the P3 port and hold the pressure in the P3 port a little.

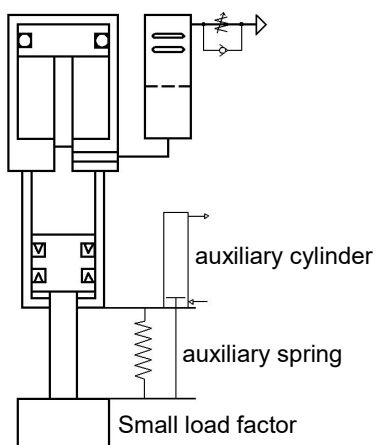
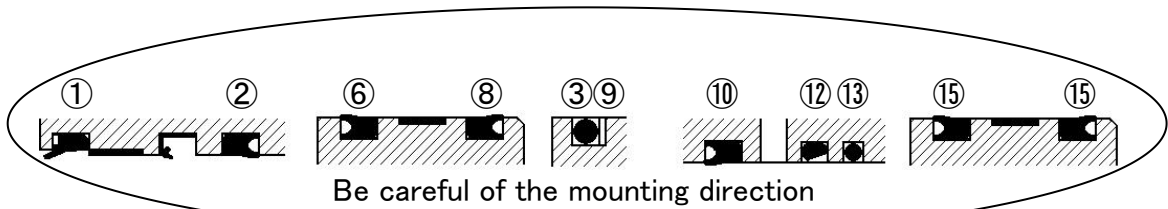
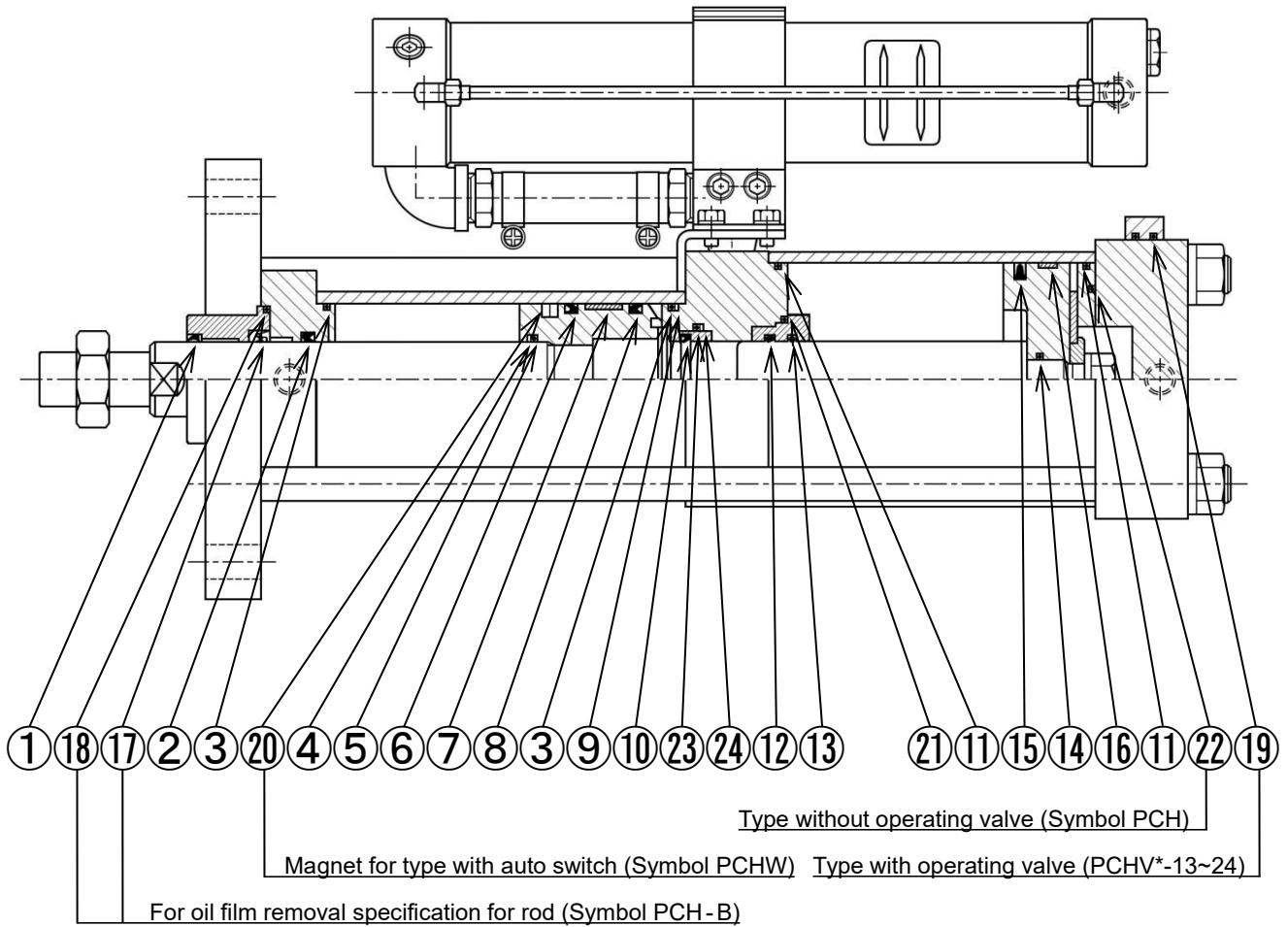

Illustration 5

## Troubleshooting guide

Situation		Cause of issue	Countermeasures	
Movements	Slow speed	Overall	Fittings, piping size are small or long	Make thicker and shorter
			Solenoid valves, silencer are small size	Make larger size
			Insufficient air supply (Large drop in pressure during operation)	Increase the size of the air piping from the air source to the device
				Install a reservoir tank
		Backward side	Heavy JIG weight	Increase compressor capacity
				Increase air pressure
				Add a auxiliary equipent (see page 20)
			The speed controller at the P1 and the P3 are excessively closed	Lighten the JIG
				Open or remove the speed controller
				Replace the type with backflow function
	Regulator for high thrust adjustment	Check the guide, slide bush and die		
		Misalignment	Replace the seal	
	Resistance due to seal wear	Delay SOL-2 OFF at start of rising		
	Switching delay of drop prevention valve due to insufficient supply air flow rate	Increase the supply air flow rate		
	Piston rod stop on the way of stroke	Forward side	The high thrust valve is turned on first	Turn on the pneumatic thrust valve first
			Insufficient high thrust stroke	Reconsider the cylinder type
		Backward side	Misalignment of device and cylinder	Check the guide, slide bush and die.
			Resistance due to seal wear	Replace the seal
Go forward once after starting backward	Booster backward speed is fast		Install a speed controller on P1	
	The high thrust valve is turned off first		Check electrical circuit	
	High load factor		Increase supply air pressure	
Intermediate stop is not possible	Stop valve seal is broken		Replace the stop valve	
	SOL of stop valve is broken		Replace the stop valve SOL	
Raises slightly at intermediate stop and stops	The workpiece is heavy		Add a timer, delay only stop valve SOL OFF by about 0.2 sec	
The cylinder does not move at all.	The defective control circuit, no air supply		Check control circuit, air supply	
	The malfunctions of pneumatic control equipment		Check the solenoid valve, speed controller, etc	
	Stop valve is broken		Replace the stop valve or SOL	
	Pneumatic Power Cylinder is broken		Inquire with us or our distributor	
High thrust	No high thrust	Compressed air is not supplied to P1	Check the regulator, high thrust valve	
		The high thrust valve is turned on first	Turn on the pneumatic thrust valve first	
		Oil is not contained, or insufficient	Add oil and adjust to proper level	
		High thrust operation at a position where there is no repulsive force	Check high thrust operation at a position with repulsive force	
	High thrust is unstable Can't be fully pressed with high thrust	Compression loss due to air mixed in oil		Slow the return of the booster by adjusting a speed controller in P1
		Struts stretch, or frames bend		Design change, or parts exchange
		High thrust start is too early		Adjust the position of high thrust start switch
		Ability lack of the cylinder		Increase the air pressure, or reconsider of the cylinder type
		Seal failure due to seal wear		Replace the seal
Oil leakage	Oil leakage from solenoid valve's exhaust ports	From all exhaust ports	There is a lot of drain in the supplied air	Remove drain with a filter, etc
		From P2	Worn seal in intermediate cover	Replace the seal (Penta seal)
		From P3	Too much or too little oil	Adjust to proper level
			The oil becomes foam and is discharged	Slow the return of the booster by adjusting a speed controller in P1
			Discharge of oil contained in exhaust air	Install the exhaust filter
		From P4	Negative pressure generation of oil due to self-weight dropping (with stop valve type)	Keep a stop valve ON when supply air stops, or drop prevention measures
			Seal failure due to seal wear	Replace the seal (Piston packing)
			Normal leakage by packing sliding	Install the exhaust filter
			High load factor	Increase supply air pressure
		Oil leakage from connection part of cylinder	Seal failure due to seal wear	
Oil color turned black	Initial wear of seals		Continue to use	
	Deterioration of oil, or drain mixed		Exchange the oil	

# Packing for PCH series



## Packing List

No.	1	2	3	4	5	6	7	8	9	10	11	12	13	14	15	16	17	18	19	20	21	22	23	24
Model	Dust seal	Y packing	O ring	Back up	O ring	Y packing	Wear ring	Y packing	Back up	Y packing	O ring	Penta seal	O ring	O ring	Y packing	Wear ring	Oil seal	O ring	O ring	Magnet	O ring	O ring	O ring	Back up
PCH-03										ISI 40 50 6		PS40	P40											
PCH-06	LBI 40	ISI 40 50 6	G75	P40	P40	PGY 80	SW80	UHP 80	G75	ISI 30 40 6	G120	PS30	P30	P20	PPD 125	SWA 125	TB4 40 55 9	G75	—	—	G60	G70	—	—
PCH-08										IDI 25 40 10		PS25	P25										P44	BR44
PCH-13										ISI 45 55 6		PS45	P45											
PCH-17	DR 60	ISI 60 70 6	G120	G60	G60	PGY 125	SW 125	UHP 125	G120	IDI 40 56 12	1517 #39	PS40	P40	P20	PGY 180	SWA 180	TB4 60 78 9	G110	P18	—	—	—	—	—
PCH-24										IDI 34 50 12		PS34	P34											
PCH-35	DSI 90 100 6	ISI 90 105 9	P140	G90	G90	PGY 150	SW 150	UHP 150	G140	IDI 34 50 12	1517 #39	PS34	P34	P20	PGY 180	SWA 180	TB4 90 115 14	G125	—	—	—	—	—	—
PCH-44										IDI 30 45 10		PS30	P30											
Q'ty	1	1	2	1	1	1	1	1	1	1	2	1	1	1	2	1	1	1	2	—	1	1	1	1

PCH-03 to 08 type uses one No.15 packing. PCH-35 and PCH-44 of all use the No.18 O-ring.

Note) Standard seal kit is No.1 to No.16 (without No.4 and No.5 because it is difficult to replace).  
 No.17 to No.24 are sold separately.  
 How to order : Seal kit for PCH - ※※

## Packing for PCS series

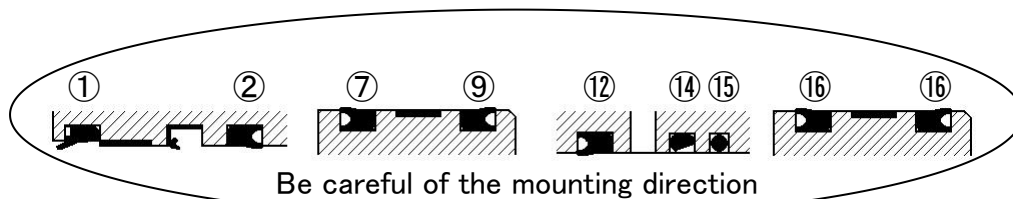
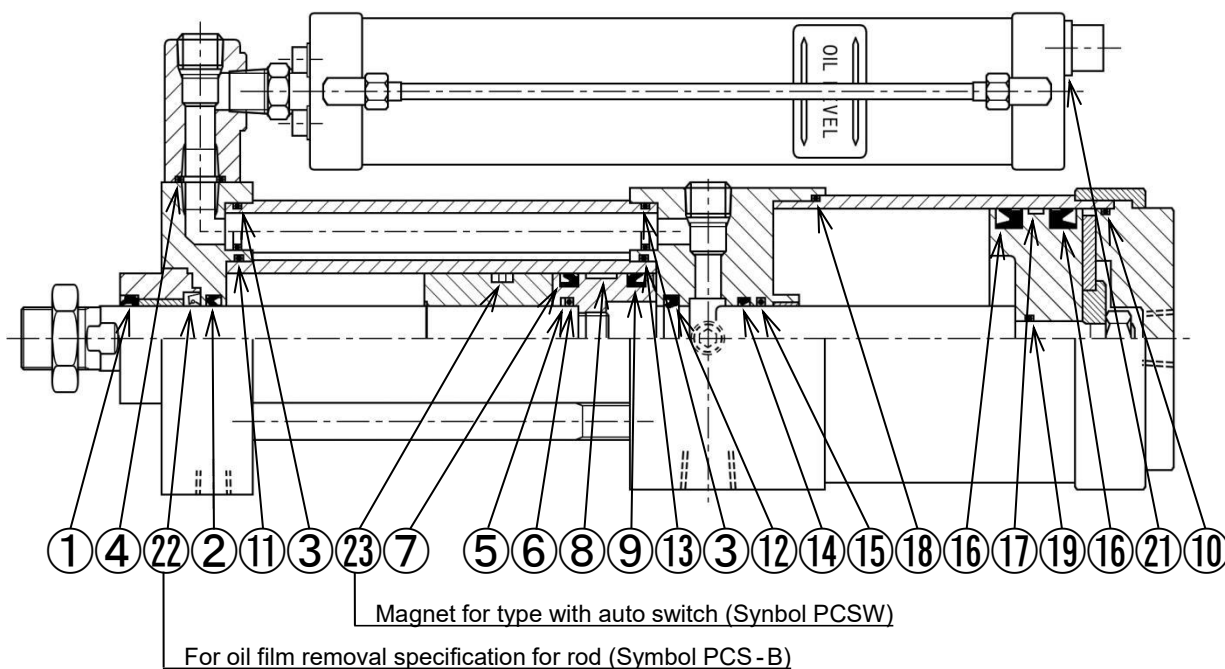

### Packing List

No.	1	2	3	4	5	6	7	8	9	10	11	12	13	14	15	16	17	18	19	21	22	23
Model	Dust seal	Y packing	O ring	O ring	Back up	O ring	Y packing	Wear ring	Y packing	O ring	O ring	Y packing	O ring	Penta seal	O ring	Y packing	Wear ring	O ring	O ring	Seal washer	Oil seal	Magnet
PCS 02	SFR	ISI	P14	P14	P25	P25	PGY	SW	UHP	S95	G60	ISI 25 33 5	G60	PS 25	P25	PGY	SWB	S	P14	TSW	TB4	—
PCS 04	25	25 33 5	P14	P14	P25	P25	50	50	50			ISI 18 26 5	90°	PS 18	P18	100	100	105		12	25 40 8	—
Q'ty	1	1	2	1	1	1	1	1	1	1	1	1	1	1	1	2	1	1	1	1	1	—

Note) Standard seal kit is No.1 to No.19 (without No.5 and No.6 because it is difficult to replace).

No.21 and No.22 are sold separately.

How to order : Seal kit for PCS- ※※

## Packing for PCM series

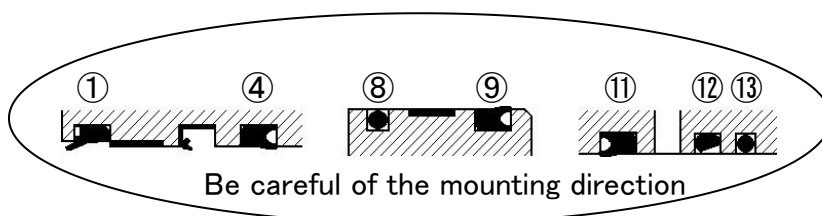
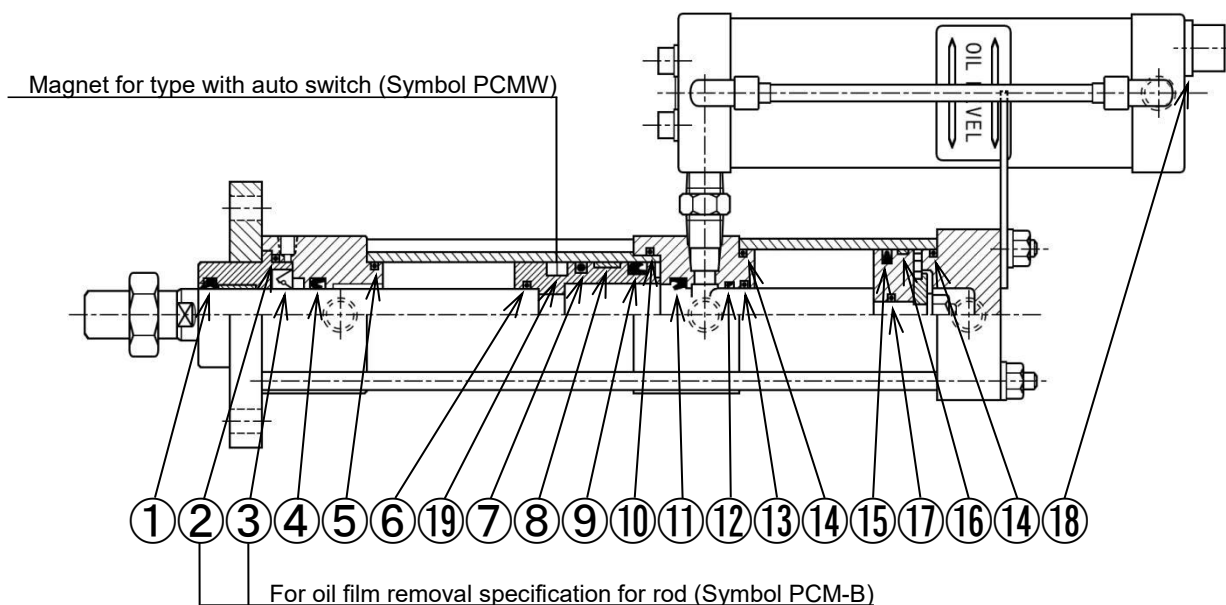

### Packing List

No.	1	2	3	4	5	6	7	8	9	10	11	12	13	14	15	16	17	18	19	
Model	Dust seal	O ring	Oil seal	Y packing	O ring	O ring	O ring	Wear ring	Y packing	O ring	Y packing	Penta seal	O ring	O ring	Piston packing	Wear ring	O ring	Seal washer	Magnet	
PCM 005	SDR	S40	TB4	PNY	S36	P20	P34	SW	OSI	G45	ISI	PS	P20	S46	PPD	SWB	P	TSW	—	
PCM 01	20		20 35 7	20				40	40 30 6		20 28 5	PS	P14							50
Q'ty	1	1	1	1	1	1	1	1	1	1	1	1	1	2	1	1	1	1	1	—

Note) Standard seal kit is No.1 to No.17 (without No.2, 3 and No.6 because it is difficult to replace).

No.18 is sold separately.

How to order : Seal kit for PCM - ※※



**HIROTAKA MFG. CO., LTD.**

HEAD OFFICE

5-89, Ikoma-cho, Kita-ku, Nagoya City, Aichi 462-0832, Japan  
Phone +81-52-991-6111 Fax +81-52-991-6115

<https://www.hirotaka.co.jp/eng/>

2026a1